

## HM012 Series

HM012 series is a mini capsule slip ring with OD 12mm (6~18 rings optional), length 15.6mm to 24.8mm. Gold to gold contact material ensures low contact resistance, low torque and reliable performance. Electrical power and signal transfer in one unit is workable for this series.



## Features

- ◆ Compact design with OD12mm, length 15.6mm to 24.8mm
- ◆ 6~18rings optional
- ◆ Transfer electrical power and signal in one unit
  - Power ring with 5A and 10A is available upon 2A rings combination for this series
- ◆ Low torque, less than 0.06N.m
- ◆ Operating smoothly and reliability
- ◆ Extremely low electrical noise
- ◆ Convenient to assembly

## Optional

- ◆ Operation speed, current & voltage
- ◆ Connector
- ◆ Type of Flange
- ◆ No. of rings
- ◆ Housing material
- ◆ Position of wire outlet
- ◆ Protection level (dust and water)
- ◆ Compatible with FORJ, RF, digital signal, analog signal, data bus protocols, Ethernet signal and so on.

## Specifications

Electrical Data		Mechanical Data	
Rated Voltage	0~240 VAC/VDC	Max. Speed	0-250RPM
Rated Current	2A/ring	Working Temperature	-20°C~+80°C
Lead Size	AWG26, Silver plated Teflon colour coded	Working Humidity	60% RH or higher
Lead Length	Standard 250mm (adjustable)	Housing Material	Engineering plastic
Dielectric Strength	500VAC@50HZ,60S	Contact material	Gold to gold
Insulation Resistance	500MΩ/500VDC	IP rating	IP51
Electrical Noise	<0.01Ω		

## Lead Wires Color Code

Ring#	1	2	3	4	5	6	7	8	9	10	11	12
Color	RED	BLK	WHT	YEL	GRN	BLU	PUP	GRY	BRN	ORN	DBLU	KHK
Ring#	13	14	15	16	17	18	19	20	21	22	23	24
Color	WHT-RED	WHT-BLK	WHT-BLU	WHT-PUP	WHT-BRN	WHT-GRN	WHT-ORN	WHT-YEL	WHT-GRY	WHT-RED	WHT-BLU	WHT-GRN

## Drawing for HM012-nA-SW

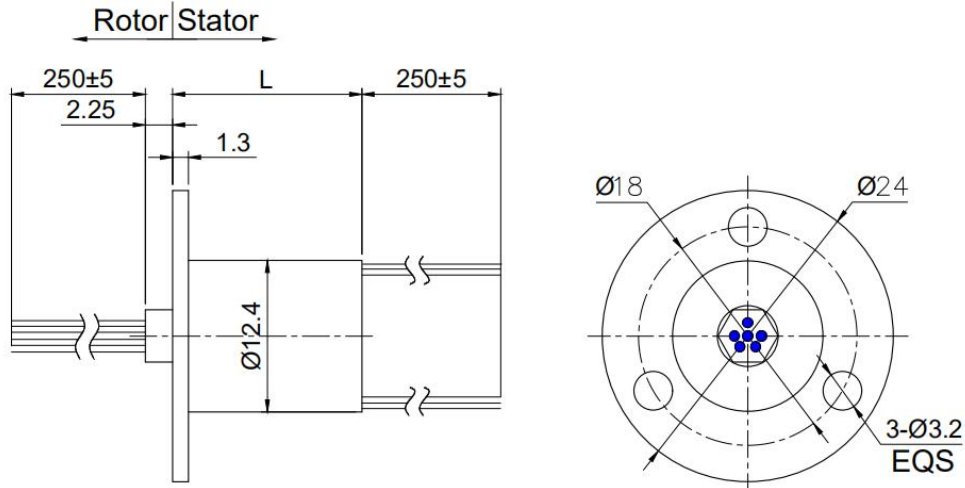

## Drawing for HM012-nA4F-SW

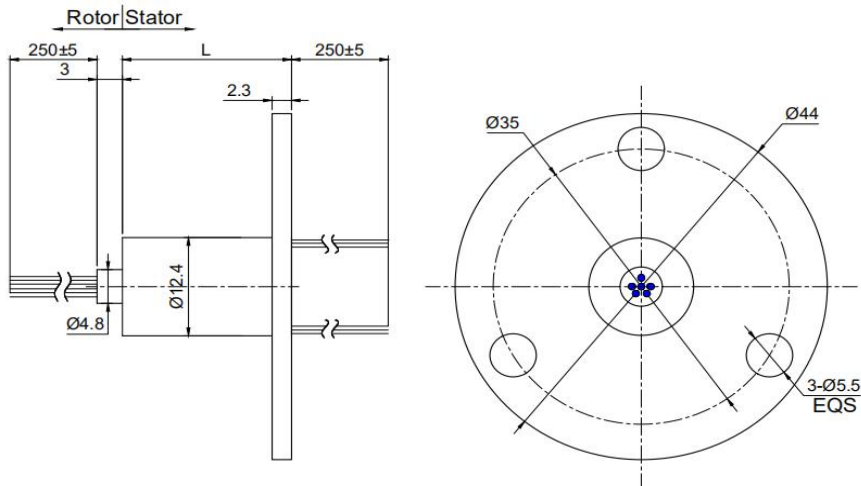

## Drawing for HM012-nB1-SW

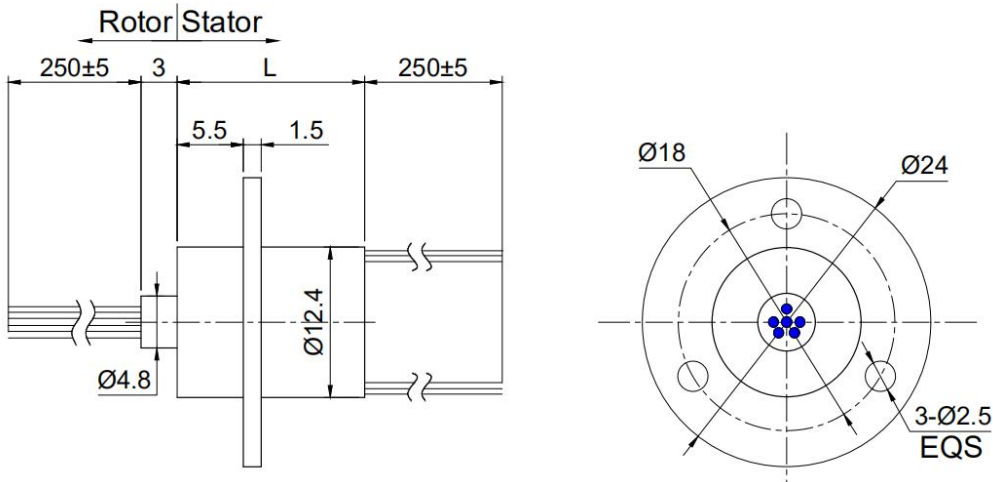

## Drawing for HM012-nB-SW

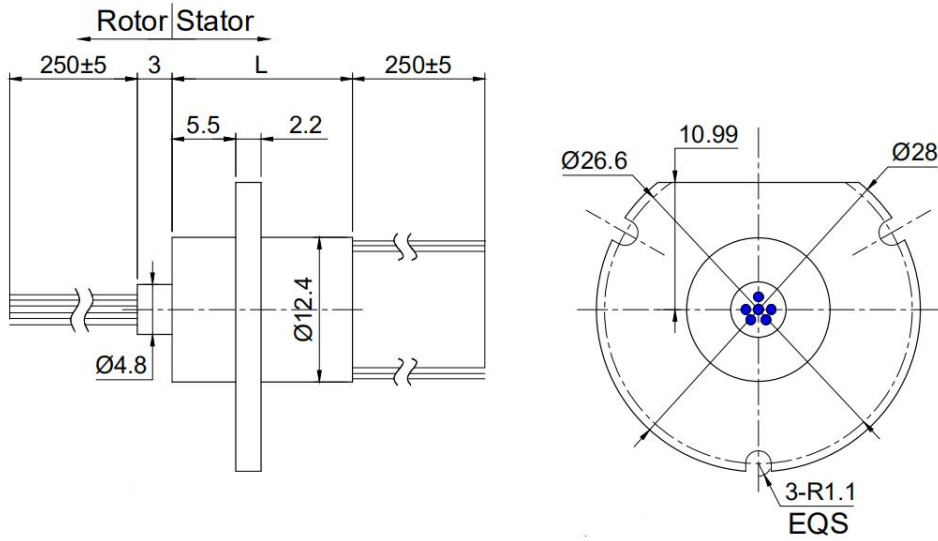

## Drawing for HM012-nQ-SW

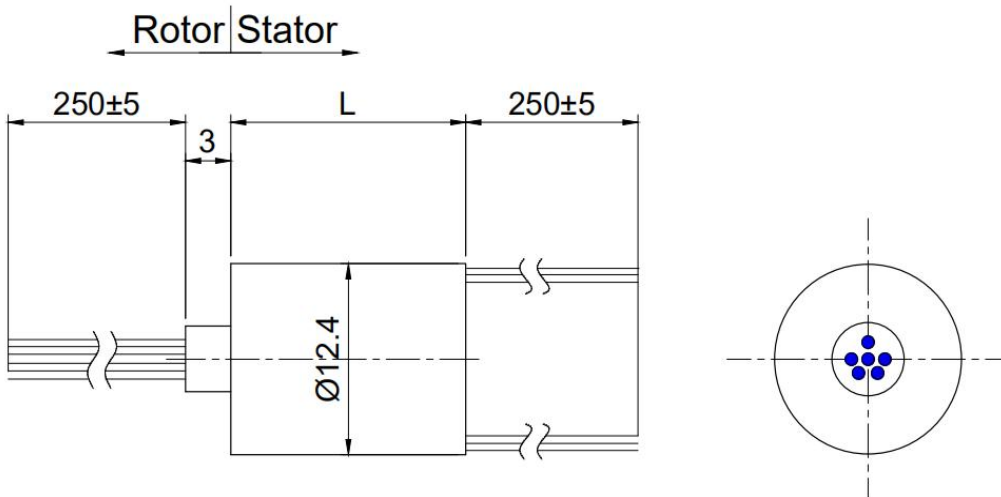

## Drawing for HM012-nA4-SW

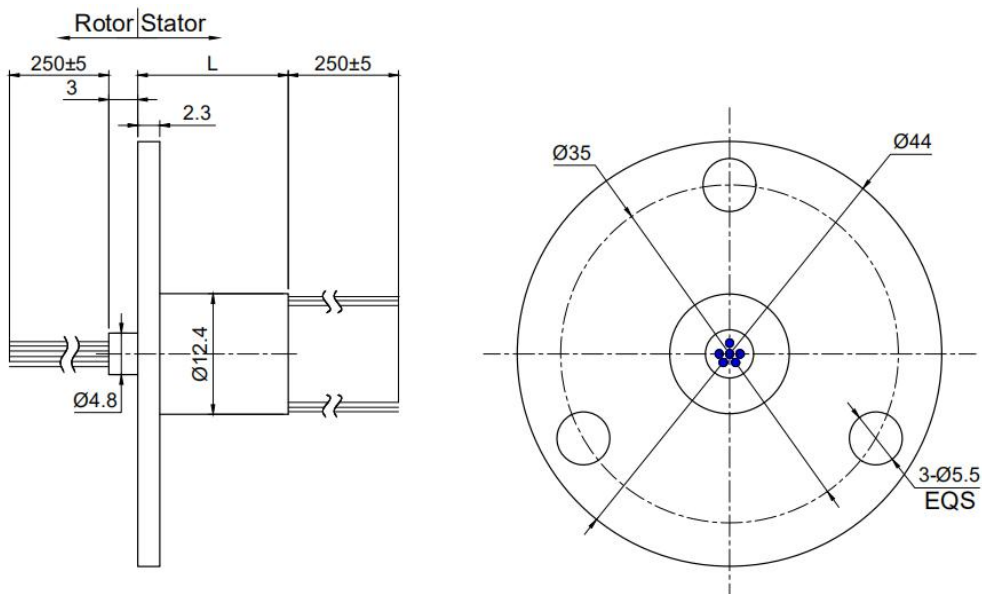

## Drawing for HM012-6A2-SW

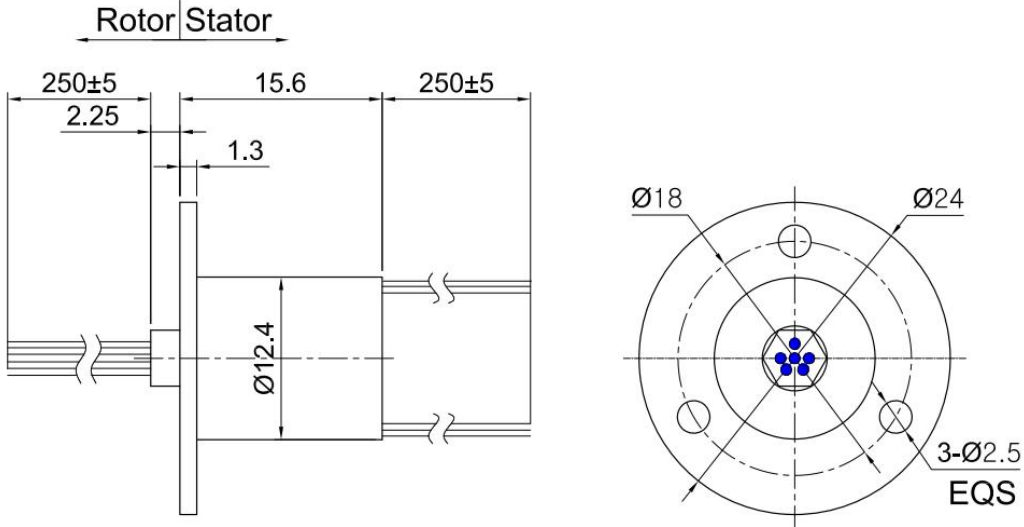

## Drawing for HM012-6B3-SW

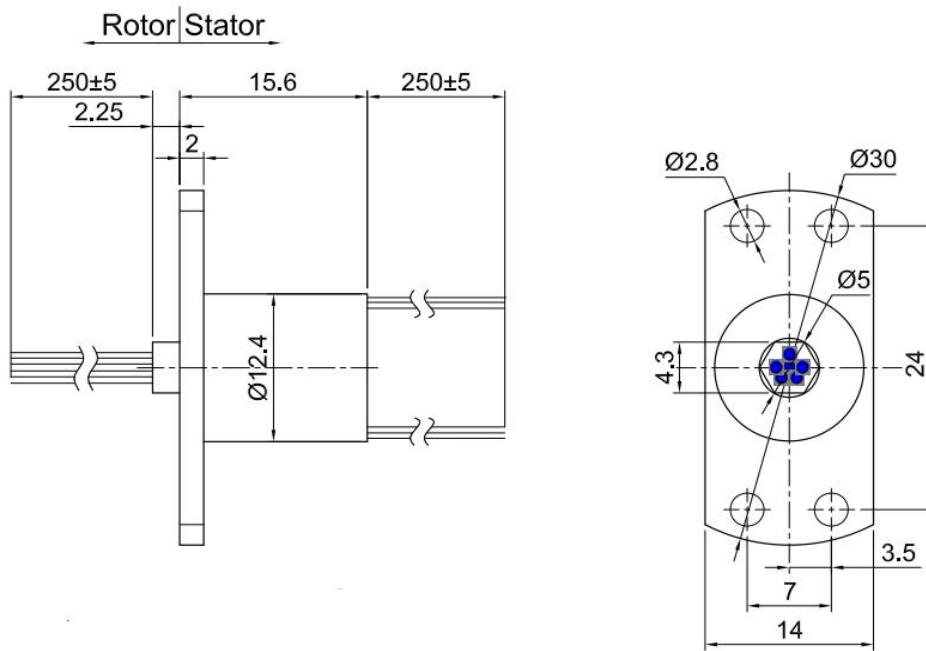

## Drawing for HM012-12A11-SW

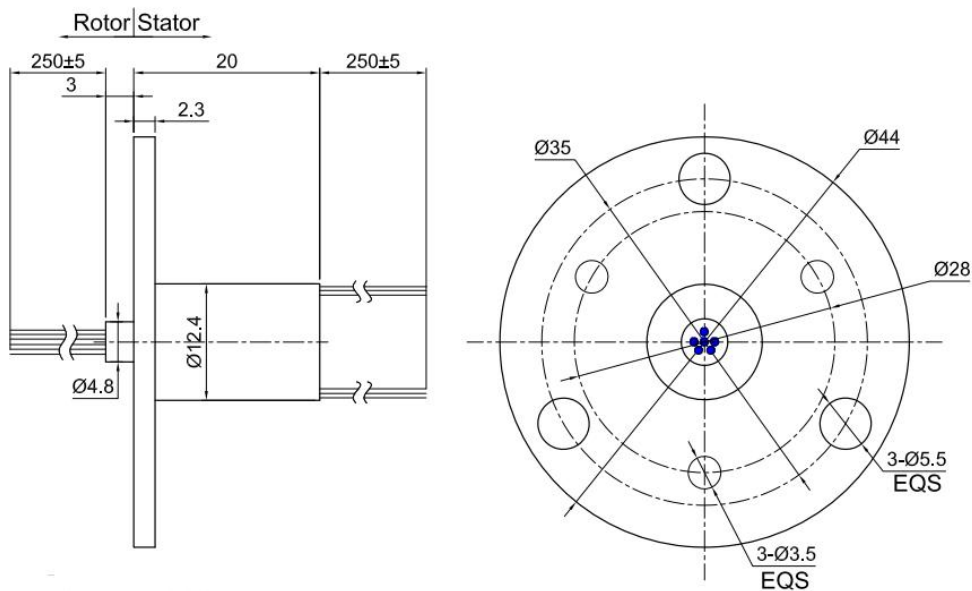

## Drawing for HM012-12A12F-SW

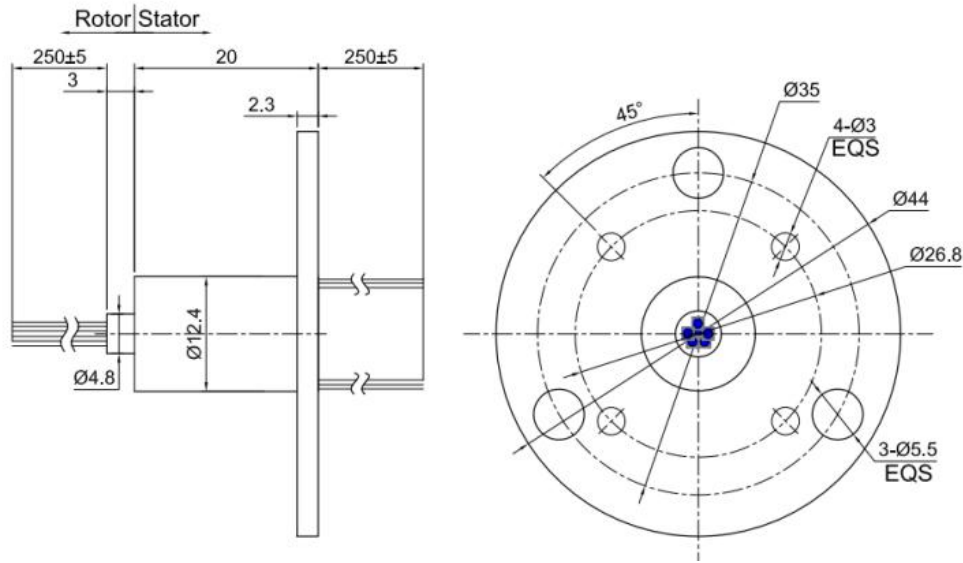

## Model List

Model	Number of Rings	Rated Current	Rated Voltage	Length (mm)
HM012-6A-SW	2	2A	0~240V	15.6
HM012-12A-SW	12	2A	0~240V	20.0
HM012-18A-SW	18	2A	0~240V	24.8
HM012-6A4F-SW	6	2A	0~240V	17.4
HM012-12A4F-SW	12	2A	0~240V	15.6
HM012-18A4F-SW	18	2A	0~240V	20.0
HM012-6B1-SW	6	2A	0~240V	15.6
HM012-12B1-SW	12	2A	0~240V	20.0
HM012-6B-SW	6	2A	0~240V	15.6
HM012-12B-SW	12	2A	0~240V	20.0
HM012-18B-SW	18	2A	0~240V	24.8
HM012-6Q-SW	6	2A	0~240V	15.6
HM012-12Q-SW	12	2A	0~240V	20.0
HM012-18Q-SW	18	2A	0~240V	24.8
HM012-6A4-SW	6	2A	0~240V	15.6
HM012-12A4-SW	12	2A	0~240V	20.0
HM012-18A4-SW	18	2A	0~240V	24.8
HM012-6A2-SW	6	2A	0~240V	15.6
HM012-6B3-SW	6	2A	0~240V	15.6
HM012-12A11-SW	12	2A	0~240V	20.0
HM012-12A12F-SW	12	2A	0~240V	20.0